

Quartz Crystal · SS4

Pin Type Crystal · 11.35 x 4.65 mm

- taped version available
- wave soldering temperature: 260 °C max.
- package height 3.6 mm max.



General Data

type	SS4 (HC49/U4H)
frequency range	3.2768 ~ 40.0 MHz (fund. AT-cut)
	27.0 ~ 64.0 MHz (3rd OT. AT-cut)
frequency tolerance at 25 °C	± 10 ppm ~ ± 30 ppm
load capacitance C_L	12 pF ~ 32 pF or series
shunt capacitance C_0	< 5 pF
storage temperature	-40 °C ~ +90 °C
drive level max.	500 μ W (100 μ W recommended)
aging	< ± 5 ppm first year

Dimensions

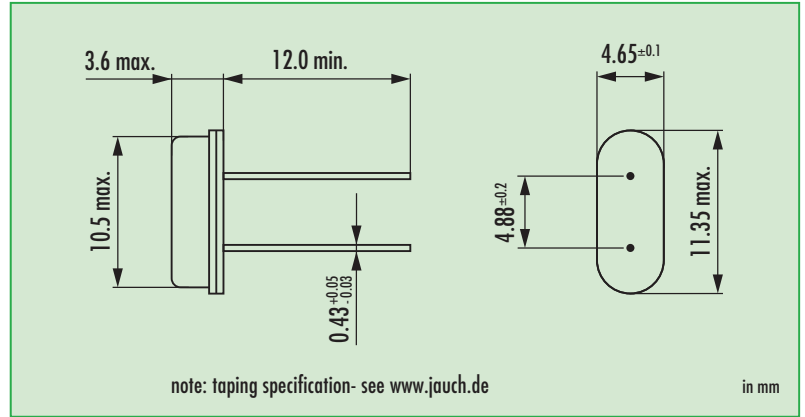

Frequency Stability vs. Temperature

		± 20 ppm	± 30 ppm	± 50 ppm	± 100 ppm	
-20 °C ~ +70 °C	STD	○ > 8.0 MHz	● ≥ 8.0 MHz	● < 8.0 MHz		
-40 °C ~ +85 °C	T1		○ ≥ 8.0 MHz	○ ≥ 8.0 MHz	○	

● standard
○ available

ESR (series resistance R_s)

frequency in MHz	vibration mode	ESR max. in Ω	ESR typ. in Ω
3.2768 ~ 3.999	fund.- AT	200	100
4.000 ~ 4.499	fund.- AT	120	60
4.500 ~ 5.999	fund.- AT	100	50
6.000 ~ 6.999	fund.- AT	80	40
7.000 ~ 9.999	fund.- AT	70	35
10.00 ~ 13.99	fund.- AT	50	25
14.00 ~ 40.00	fund.- AT	40	20
27.00 ~ 64.00	3rd OT - AT	120	80

Order Information

Q	frequency	type	load capacitance in pF	stability at 25 °C	/	stability vs. temp. range	option
Quartz	3.2768 ~ 64.0 MHz	SS4	12 pF ~ 32 pF S for series	30 = ± 30 ppm std		see table	blank = -20 °C ~ +70 °C T1 = -40 °C ~ +85 °C FU = for fundamental frequencies ≥ 20 MHz 30T = 3rd overtone MP = middle pin TR = taped TA = taped, ammo pack KIS = spacer IS = insulation spacer LL = lead length in mm PT = plastic tray

Example: Q 30.0-SS4-30-30/30-FU (Suffix LF = RoHS compliant / Pb free pins or pads)



Quartz Crystal · SS4

Load Capacitance Codes

12 pF: a	18 pF: f	30 pF: .
13 pF: v	20 pF: c	32 pF: e
14 pF: x	22 pF: g	series: s
15 pF: j	24 pF: d	T: 3rd OT
16 pF: b	25 pF: r	
17 pF: t	27 pF: w	

example 4.0 MHz / 12 pF: 4a000

Wave Soldering Profile

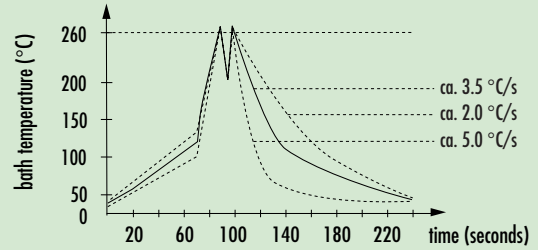

Taping Specification

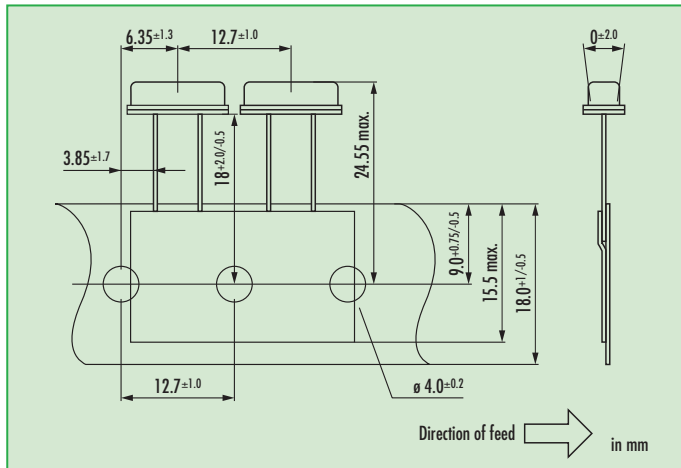

Marking

frequency with load capacitance code
company code / date code / internal code

	Jan.	Febr.	Mar.	Apr.	May	June	July	Aug.	Sept.	Okt.	Nov.	Dec.
2005	A	B	C	D	E	F	G	H	J	K	L	M
2006	N	P	Q	R	S	T	U	V	W	X	Y	Z
2007	a	b	c	d	e	f	g	h	i	k	l	m
2008	n	p	q	r	s	t	u	v	w	x	y	z